

HIAB XS 088 Range 6-9 tm

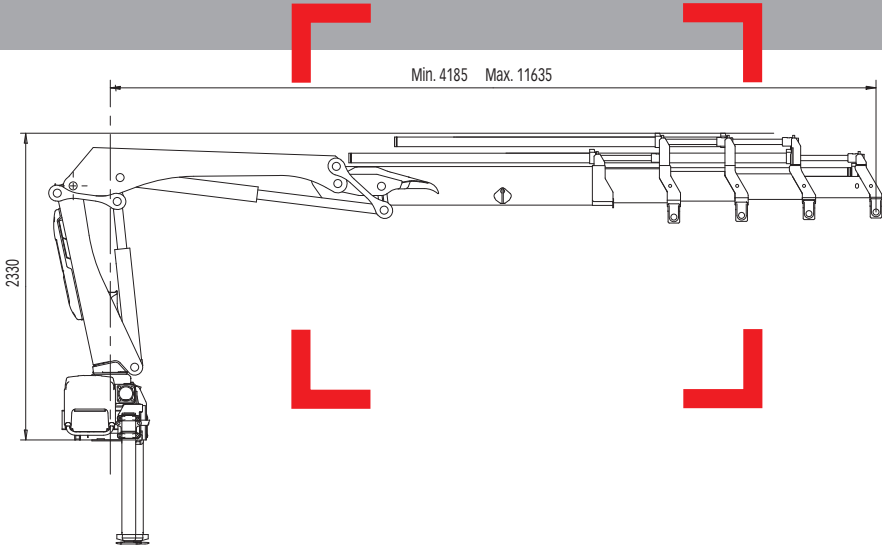

Basic data

HIAB XS 088 Basic data

Technical data

	B-3 CL	B-2 Duo	E-4 HiDuo	E-5 HiDuo
Max. lifting capacity (kNm)	65	74	77	74
Outreach - hydraulic extensions (m)	9.7	7.7	11.6	13.7
Outreach - manual extensions (m)	11.8	9.7 - 11.8	13.7	-
Outreach / Lifting capacity, standard (m / kg)	3.1 / 2300	2.9 / 2700	2.2 / 3500	2.2 / 3250
	3.9 / 1700	3.8 / 2000	4.2 / 1860	4.3 / 1760
	5.5 / 1160	5.4 / 1380	5.8 / 1260	5.9 / 1180
	7.3 / 840	7.3 / 1020	7.7 / 900	7.8 / 820
	9.2 / 660	-	9.6 / 700	9.7 / 600
	-	-	11.6 / 560	11.7 / 480
	-	-	-	13.7 / 400
Slewing angle	400 - 406°	400 - 406°	400 - 406°	400 - 406°
Height in folded position (mm)	1990	1990	2000	2000
Width in folded position (mm)	2190	2170	2300	2375
Installation space needed (mm)	710	640	660	740
Weight - "standard" crane without stabilizers (kg)	1170	1080	1260	1340
Weight - stabilizer equipment (kg)	135 - 205	135 - 205	135 - 205	135 - 205

HIAB XS 088 E-5 HiDuo

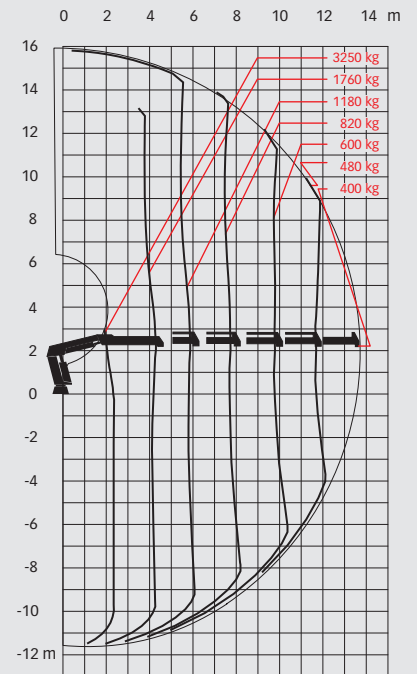
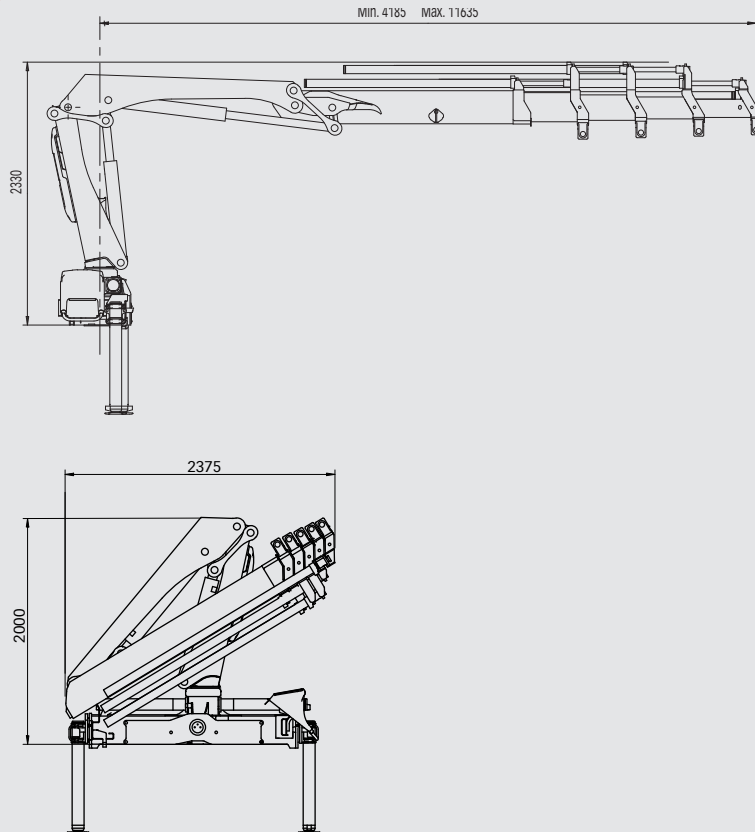

Disclaimer

Hiab cranes have been built to meet the highest standards of safety and service life and have been thoroughly tested. Strength calculations for this model have been carried out in accordance with EN13001. Hiab's certified Quality Assurance System complies with the ISO 9001. Some of the items in our literature may be extra equipment. Certain applications may require an official permit. We reserve the right to change technical specifications without prior notice. Hiab cranes produced for EU-countries are CE-marked and comply with the European Standard EN 12999.